

AEROPRO

OPERATING INSTRUCTIONS FOR FASTENER DRIVING TOOLS OPERATED BY COMPRESSED AIR



AIR-POWERED FRAMING COIL NAILER Model No.: CN83



IMPORTANT:

Read all safety rules and operating Instructions carefully before first use it. Keep this Manual for future reference.

Residual risks

Even when the tool is used as prescribed it is not possible to eliminate all residual risk factors. The following hazards may arise in connection with the tool's construction and design:

- Damage to hearing if effective hearing protection is not worn.
- Health defects resulting from vibration emission if the power tool is being used over longer period of time or not adequately managed and properly maintained.
- Wear eye protection.



TABLE OF CONTENTS:QUICK START GUIDE

- TECHNICAL SPECIFICATIONS
- SAFETY GUIDELINES
- KEY PARTS DIAGRAM
- IMPORTANT INFORMATION
- TYPES OF FASTENERS
- OPERATING INSTRUCTIONS
- MAINTENANCE
- TROUBLESHOOTING
- EXPLODED VIEW
- PARTS LIST

2017

TECHNICAL SPECIFICATIONS:

Magazine capacity(QTY.)	225-300pcs
Nailer	Drives Fastener size: Dia.2.55~3.3mm Nail length: 50(2")-83mm(3-1/4")
Operating pressure:	70 to120 PSI(4.8 to 8.3 bar)
Maximum pressure:	120PSI (8.3bar)
Air inlet:	3/8"(10mm)
Dimensions:	12.4"x14.13"x5.37"(315X359X136.5mm)
Weight:	3.98kgs(8.75lb)

SCFM: Standard Cubic feet per minute (the volumetric flow rate of air corrected to standardized conditions of temperature and pressure).

Environmental Responsibilities

Please recycle unwanted materials instead of disposing of them as waste. All tools, hoses and packaging should be sorted, taken to the local recycling centre and disposed of in an environmentally safe way.

Safety guidelines

This manual contains information that relates to protecting personal safety and preventing equipment problems. It is very important to read this manual carefully and understand it thoroughly before using the product. The symbols listed below are used to indicate this information.



DANGER!

Potential hazard that will result in serious injury or loss of life.



WARNING!

Potential hazard that could result in serious injury or loss of life.



CAUTION!

Potential hazard that may result in moderate injury or damage to equipment.

Note-The word "note" is used to inform the reader of something he/she needs to know about the tool.

PERSONAL SAFETY

These precautions are intended for the personal safety of the user and others working with the user. Please take time to read and understand them.



DANGER!

Potential hazard that will result in serious injury or loss of life.

Keep children away from the work area. Do not allow children to handle power tools.

Keep air hose away from heat, oil, and sharp edges. Check air hose for wear before each use and ensure that all connections are proper. Always ensure that the workpiece is firmly secured leaving both hands free to control the tool. Always ensure that the tool has stopped before putting it down after use, in the interest of safety and to prevent possible damage to the tool/user.

Keep proper footing at all times in order to ensure correct balance.



Do not use oxygen or any other combustible or bottled gas to power air-powered tools. Failure to observe this warning can cause explosion and serious personal injury or death.

Use only the compressed air to power the air-powered tools. Use a minimum of 25'(7.6m) of hose to connect the tools to the compressor. Failure to comply will result in serious injury or loss of life.



Risk of electric shock: Do not expose a compressor to rain. Store it indoors. Disconnect the compressor from power source before servicing. Compressor must be grounded. Do not use grounding adaptors.



Risk of personal injury: Do not direct compressed air from the air hose toward the user or other personnel.



Risk of inhalation: Never directly inhale the air produced by the compressor.



Risk of bursting: Do not adjust the pressure switch or safety valve for any reason. They have been preset at

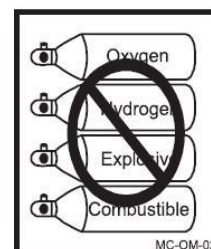

the factory for this compressor's maximum pressure. Tampering with the pressure switch or the safety valve may cause personal injury or property damage.



Risk of burns: The pump and the manifold generate high temperatures. In order to avoid burns or other injuries, do not touch the pump, the manifold or the transfer tube while the compressor is running. Allow the parts to cool down before handling or servicing. Keep children away from the compressor at all times.



Risk of bursting: Make sure the regulator is adjusted so that the compressor outlet pressure is set lower than the maximum operating pressure of the tool. Before starting the compressor, pull the ring on the safety valve to make sure the valve moves freely.



Drain water from tank after each use. Do not weld or repair tank. Relieve all pressure in the hose before removing or attaching accessories.

WARNING!

Potential hazard that could result in serious injury or loss of life.

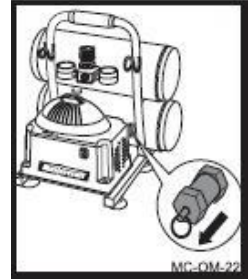

Do not allow unskilled or untrained individuals to operate the air powered tools.

Do not use the air powered tools for any task other than that it is designed to perform.

Do not use the air tools unless you have been trained to do so. Only a qualified person should use the tool.

Locate the compressor in a well-ventilated area for cooling, and must be a minimum of 12"(31cm) away from the nearest wall.

Protect the air hose and the power cord from damage and puncture. Inspect them for weak or worn spots every week, and replace them if necessary .

Always wear hearing protection when using the air compressor. Failure to do so may result in hearing loss.

Do not carry the compressor while it is running.

Do not operate the compressor if it is not in a stable position.

Do not operate the compressor on a rooftop or in an elevated position that could allow the unit to fall or be tipped over.

Always replace a damaged gauge before operating the unit again.



CAUTION!

Potential hazard that may result in moderate injury or damage to equipment.

Always ensure that the tool has stopped before connecting to the air supply.

Do not wear watches, rings, bracelets, or loose clothing when using any air tool.

Do not overload the tool. Allow the tool to operate at its optimum speed for maximum efficiency.

Do not use a tool that is leaking air, with missing or damaged parts, or that requires repairs. Verify that all screws are securely tightened.

For optimal safety and tool performance, inspect the tool daily in order to ensure free movement of the trigger, safety mechanisms, and springs.

Always keep your air tools clean and lubricated. Daily lubrication is essential to avoid internal corrosion and possible failures.

Ensure the floor is not slippery and wear non-slip shoes. Floors should be kept clean can clear.

Always follow all workshop safety rules, regulations, and conditions when using the tools.

Carry the tool by the handle only. Do not carry the tools with a finger on the trigger. Do not carry the tool by the hose, magazine or any other parts.

Do not use the tool near or below freezing temperatures, as doing so may cause tool failure.

Do not store the tool in a freezing environment to prevent ice formation on the operating valves of the tool, as doing so may cause tool failure.

Handling and storage of oil: Use with adequate ventilation. Avoid contact of oil with eyes, skin, and clothing. Avoid breathing spray or mist. Store in a tightly closed container in a cool, dry, well-ventilated area free from incompatible substances.



CAUTION!

Potential hazard that may result in moderate injury or damage to equipment.

Disconnect tool from the air supply and turn off the compressor before performing any maintenance, or changing accessories, when the tool is not in use, when it is being handed to another person, and when it is left unattended. Failure to comply may result in moderate injury or damage to equipment.

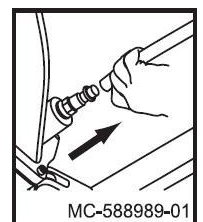



Use safety goggles and ear protection:

Wear safety glasses with side shields when operating the tool/compressor and verify that others in the work area are also wearing safety glasses.

Requirements and must provide protection from flying particles from the front and the sides.

Air powered tools are loud and the sound can cause hearing damage. Always wear ear protection to prevent hearing damage and loss. Failure to comply may result in moderate injury.

NOTE: Recycle unwanted materials rather than disposing of them as waste. Sort the tools, hoses, and package into specific categories and take to the local recycling centre or dispose of them in an environmentally safe way.

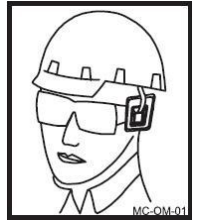

KEY PARTS DIAGRAM

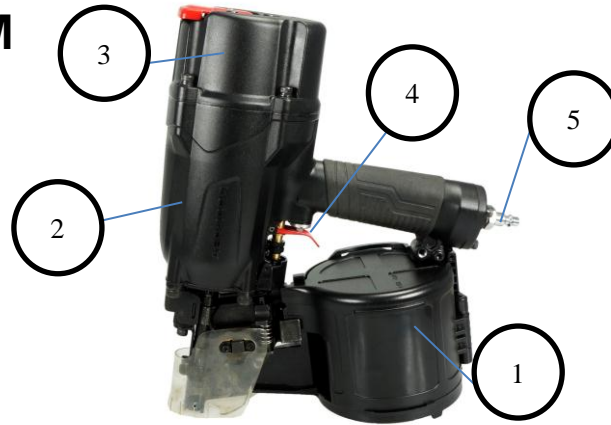

No.	Description	No.	Description
1	Magazine	4	Trigger
2	Gun Body	5	Air inlet plug
3	Cylinder Cap		

IMPORTANT INFORMATION

Compatible compressors

GUIDELINES FOR PROPER USE AND OPERATION

Be sure to use a proper air compressor with air powered tools.

General use

This nailer drives nail 50mm (2") to 83mm(3-1/4") , It feature a die-cast aluminum housing and a comfortable handle for optimal control and comfort, even during extended use. It is well balanced for stability, and ergonomically designed with a longer handle for ease of operation. It also features a hardened driver blade for longer life, and economical air consumption with low noise. This air powered nailer is specifically designed for professional work.

Air system

- Always use clean, dry, regulated, compressed air at 4.8 to 8.3bar(70 to 120psi).
- Do not exceed the maximum or minimum pressures. Operating the tool at the wrong pressure(too low or too high) will cause excessive noise or rapid wear of tool.



WARNING!

Potential hazard that could result in serious injury or loss of life.

- Keep hands and other parts of the body away from the tools discharge and working areas when connecting the air supply. Failure to comply could lead to serious injury or loss of life.
- It is recommended that a filter-regulator-lubricator is used and located as close to the tool as possible.
- If a filter-regulator-lubricator is not installed, place up to 6 drops of compressor oil into the inlet plug before each use.

- If a filter-regulator-lubricator is installed, keep the air filter clean. A dirty filter will reduce the air pressure to the tool, which will cause reduction in power, efficiency, and general performance.
- For optimal performance, install a quick connector to the tool and a quick coupler on the hose, if applicable.
- Verify that all of the connections in the air supply system are sealed in order to prevent air from leaking.

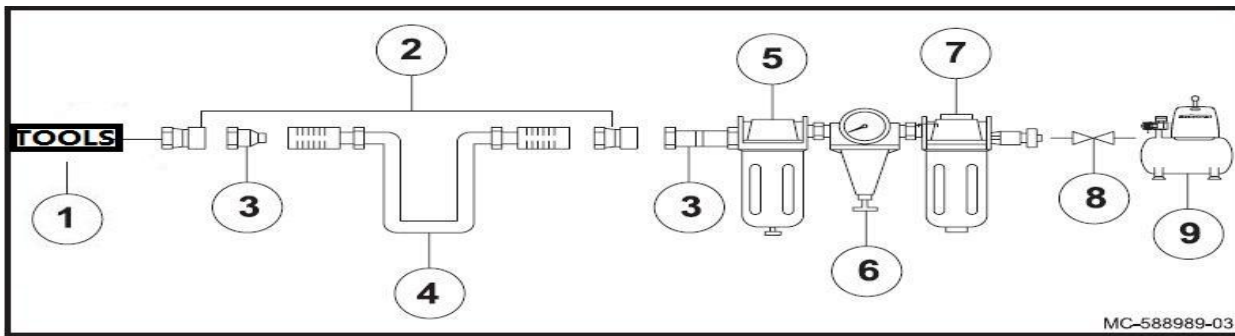

NO.	Description	NO.	Description	NO.	Description
1	VALU-AIR Air powered Framing	4	Air Hose	7	Filter
2	Quick connector	5	Lubricator	8	Cut-off valve
3	Quick coupler	6	Regulator(0 to 8.3 Bar)	9	Air compressor



WARNING!

Potential hazard that could result in serious injury or loss of life.

Do not use the tool if it is not in proper working order.

Do not use oxygen, carbon dioxide or any other combustible, or bottled gas to power this tool.

Do not use this tool in the presence of any flammable liquids or gases.

Keep hands and other parts of the body away from the firing head during use.

Do not point the tool towards the operator or other people.

Never attempt to clear a jammed fastener while the air hose is connected.

Do not drive a fastener on top of an existing fastener. Failure to comply could lead to serious injury or loss of life.

TYPES OF FASTENERS

Please see the TECHNICAL SPECIFICATIONS.



WARNING!

Potential hazard that could result in serious injury or loss of life.

- The use of any other types of fasteners will cause the tool to jam. Failure to comply could lead to serious injury or loss of life.

OPERATING INSTRUCTIONS

4.1 Preparing a tool for first time operation

Please Read and observe these Operating Instruction before using the tool. Basic safety measures should always be strictly followed to protect against damage to the equipment and personal injury to the user or other people working in the vicinity of operation.

4.2 Connection to the compressed air system

Ensure that the pressure supplied by the compressed air system does not exceed the maximum allowable pressure of the fastener driving tool. Set the air pressure initially to the lower value of the recommended allowable pressure (see TECHNICAL DATA). Empty the magazine to prevent a fastener from being ejected at the next stage of work in the event that internal parts of the fastener driving tool are not in the starting position following maintenance and repair work or transportation. Connect the fastener driving tool to the compressed air supply using suitable pressure hose equipped with quick-action connectors. Check for proper functioning by applying the muzzle of the fastener driving tool to a piece of wood or wooden material and actuating the trigger once or twice.

4.3 Filling the magazine

Only those fasteners specified under TECHNICAL DATA (see 1.1) may be used

When filling the magazine, hold the tool so that the muzzle is not pointing towards the operator or any other person or animals.

4.4 Handling the tool

Pay attention to **2-Special Reference**-of these operating instructions.

Having checked that the fastener driving tool is functioning correctly, apply the tool to a work piece and actuate the trigger.

Check whether the fastener has been driven into the work piece in accordance with the requirements.

- if the fastener is protruding, increase the air pressure in increments of 0.6 bar, checking the result after each new adjustment;
- if the fastener is driven into an excessive depth reduce the air pressure in increments of 0.6 bar until the result is satisfactory.

You should endeavor in any event to work with the lowest possible air pressure. This will give you three significant advantages;

- 1.energy will be saved, 2.less noise will be produced, 3.a reduction in fastener driving tool wear will be achieved.

Avoid triggering the fastener driving tool if the magazine is empty.

Any defective or improperly functioning fastener driving tool must immediately be disconnected from the compressed air supply and passed to a specialist for inspection.

In the event of longer breaks in work or at the end of the working shift, disconnect the tool from the compressed air supply and it is recommended to empty the magazine.

The compressed air connectors of the fastener driving tool and the hoses should be protected against contamination, the ingress of coarse dust chips, sand etc, will result in leaks and damage to the fastener driving tool and the couplings.



DANGER! Potential hazard that could result in serious injury or loss of life

Disconnect the tool from the compressed air source before loading fasteners.

Do not point the tool towards the operator or other people while changing fasteners.

Do not hold the tool with the trigger depressed while changing the fasteners. Failure to comply will lead to serious injury or loss of life.



WARNING! Potential hazard that could result in serious injury or loss of life.

CAUTION!

Potential hazard that may result in moderate injury or damage to equipment.

Operate the tool with the utmost care when connected with the air compressor.

Failure to comply may result in moderate injury or damage to equipment.

Clearing a jammed fastener

To clear a jammed fastener:

- Disconnect the tool from the air supply line.
- Remove the fasteners that are stored in the tool's magazine.



WARNING!

Potential hazard that could result in serious injury or loss of life.

- Disconnect the magazine from the tool and remove the non-jammed fasteners from the tool before clearing a jammed fastener. The fasteners are under pressure and failure to comply will cause them to be fired out of the tool causing serious injury.
- Do not point the tool towards the operator or other people. Serious personal injury could result if these instructions are not followed.
- Use pliers or any appropriate tool to remove the jammed fastener.
- Reload the fasteners into the tool magazine.
- Reconnect the air line to the tool's air inlet.
- Test fire 3 to 5 fasteners into a piece of scrap wood in order to ensure proper operation.

5. Maintenance

Disconnect the tool from the compressor before adjusting, clearing jams, servicing & maintenance, relocating and during non operation. Regular lubrication, if your tool without using the in-liner automatic oilier, place 2 or 6 drops of pneumatic tool oil into the air inlet before each work day or after 2 hours of continuous use depending in the characteristic of workpiece or type of fasteners.

Air-operated tools must be inspected periodically, and worn or broken parts must be replaced to keep the tool operating safely and efficiently. Check and change all worn or damaged O-ring, Seals, etc. Tighten all the screws and caps to avoid personal injury. This should be done by an expert. Make regular inspection for free movement of trigger, Spring and safety mechanism to assure safe system is complete and functional: no loose and missing parts, no building or stocking parts. Keep magazine and nose of tool clean and free of any dirt lint or abrasive particles. When temperatures are below freezing, tools should be kept warm by any convenient, safe method.

6. Troubleshooting (See Table 1)

The following chart lists common operating system issues and solutions. please read it carefully and follow all instructions closely.



DANGER! Potential hazard that could result in serious injury or loss of life.

If any of the following symptoms appear while the tool is in use, turn it off and disconnect it from the air supply immediately. Failure to comply will lead to serious injury or loss of life.

Disconnect the tool from the air supply before making any adjustments.

Repairs must be performed by a qualified service technician only.

SYMPTOM	PROBLEM	SOLUTIONS
Air leak near top of tool or in trigger area	<ol style="list-style-type: none"> 1. O-ring in trigger valve are damage. 2. Trigger valve head are damage. 3. Trigger valve stem ,seal or O-ring are damaged. 	<ol style="list-style-type: none"> 1. Check and replace O-ring. 2. Check and replace. 3. Check and replace trigger valve stem, seal or O-ring
Air leak near bottom of tool.	<ol style="list-style-type: none"> 1. Loose screws. 2. Worn or damaged O-rings or bumper. 	<ol style="list-style-type: none"> 1. Tighten screws. 2. Check and replace O-rings or bumper.
Air leak between body and cylinder cap.	<ol style="list-style-type: none"> 1. Loose screws. 2. Worn or damaged O-rings or seals. 	<ol style="list-style-type: none"> 1. Tighten screw. 2. Check and replace O-rings or bumper.
Blade driving fastener too deep.	<ol style="list-style-type: none"> 1. Worn bumper. 2. Air pressure is too high. 	<ol style="list-style-type: none"> 1. Replace bumper. 2. Adjust the air pressure.
Tool does not operate well: can not drive fastener or operate sluggishly.	<ol style="list-style-type: none"> 1. Inadequate air supply. 2. Inadequate lubrication. 3. Worn or damaged O-rings or seals. 4. Exhaust port in cylinder head is blocked. 	<ol style="list-style-type: none"> 1. Verify adequate air supply. 2. Place 2 or 6 drops of oil into air inlet. 3. Check and replace O-rings or seal. 4. Replace damaged internal parts.
Tool skips fasteners.	<ol style="list-style-type: none"> 1. Worn bumper or damaged spring. 2. Dirt in front plate. 3. Dirt or damage prevents fasteners from moving freely in magazine. 4. Worn or dry O-ring on piston or lack of lubrication. 5. Cylinder cover seal leaking. 	<ol style="list-style-type: none"> 1. Repalce bumper or pusher spring. 2. Clean drive channel on front plate. 3. Magazine needs to be cleaned. 4. O-ring need to be replaced. And lubricate. 5. Replace Sealing washer.
Tool jams.	<ol style="list-style-type: none"> 1. Incorrect or damaged fasteners. 2. Damaged or worn driver guide. 3. Magazine or nose screw loose. 4. Magazine is dirty. 	<ol style="list-style-type: none"> 1. Change and use correct fastener. 2. Check and replace the driver. 3. Tighten the magazine. 4. Clean the magazine.

Table 1

CN83 Explosive View and Parts list

Issue date:	2017/02/15
Version no.:	B/0

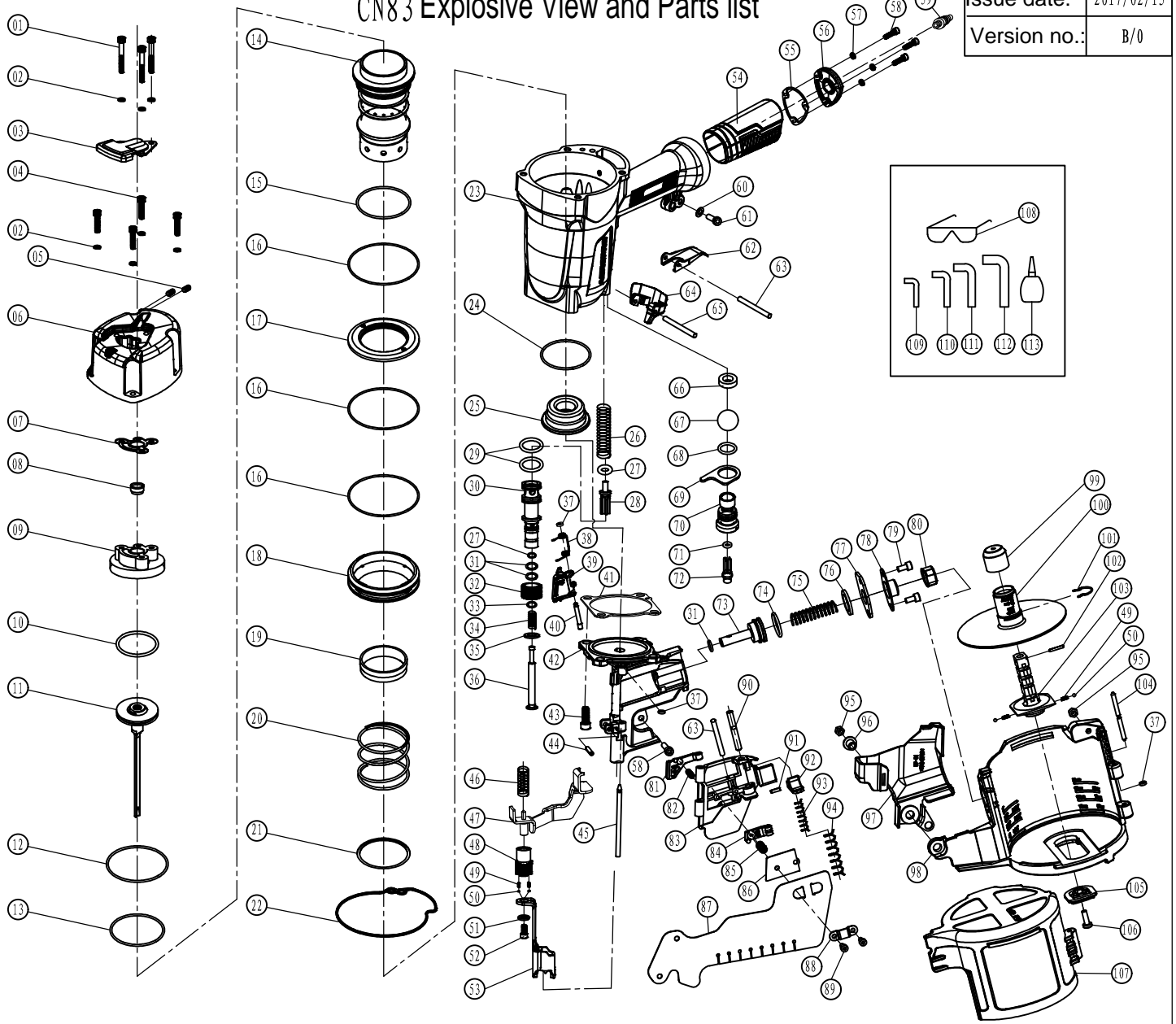

No.	Description	Qty.	No.	Description	Qty.	No.	Description	Qty.	No.	Description	Qty.
01	HEX. SOCKET HD. BOLT M6 X 45	3	30	VALVE	1	59	AIR PLUG NPT 3/8	1	88	PLATE	1
02	WASHER 6	7	31	O-RING 9X1.8	3	60	WASHER 5	1	89	HEX. SOCKET HD. BOLT M4 X 8	2
03	TOP COVER	1	32	VALVE BUSHING	1	61	HEX. SOCKET HD. BOLT M5X25	1	90	LOCK SHAFT	1
04	HEX. SOCKET HD. BOLT M6X30	4	33	O-RING 6.1X1.8	1	62	TRIGGER	1	91	ROLL PIN D3 X 10	1
05	BOLT M5x8	2	34	TRIGGER SPRING	1	63	ROLL PIN D3 X 30	2	92	GUIDE LOCK	1
06	EXHAUST COVER	1	35	WASHER	1	64	SAFETY SEAT	1	93	SPRING	1
07	GASKET	1	36	ROD	1	65	ROLL PIN D3 X 45	1	94	SPRING	1
08	EXHAUST VALVE	1	37	FEEDER SHAFT RING	3	66	VALVE PACKING	1	95	NUT M5	2
09	HEAD CAP AND GASKET SET	1	38	FEEDER SPRING	1	67	STEEL BALL	1	96	SLEEVE	1
10	O-RING 50X3.55	1	39	FEEDER	1	68	O-RING 11.2X1.85	1	97	GUARD	1
11	PISTON	1	40	FEEDER SHAFT	1	69	VALVE PLATE	1	98	MAGAZINE	1
12	O-RING 79.3X2.5	1	41	GASKET	1	70	TRIGGER VALVE BUSHING	1	99	HOLDER CAP	1
13	O-RING 69.3X2.5	1	42	NOSE	1	71	O-RING 2.8X1.8	1	100	NAIL HOLDER	1
14	CYLINDER	1	43	HEX. SOCKET HD. BOLT M8X25	4	72	TRIGGER PLUNGER	1	101	RATCHET SPRING	1
15	O-RING 62.8X2.65	1	44	ROLL PIN D4 X 20	1	73	FEED PISTON	1	102	ROLL PIN D2.5	1
16	O-RING 92.5X2	3	45	NAIL GUIDE SHAFT	1	74	O-RING 22X2.4	1	103	HOLDER SHAFT	1
17	COLLAR	1	46	SPRING	1	75	FEED SPRING	1	104	PIN	1
18	COLLAR	1	47	PUSHING LEVER	1	76	BUMPER	1	105	COVER PLATE	1
19	CYLINDER RING	1	48	ADJUSTER	1	77	FEED PISTON COVER	1	106	HEX.SOCKET BOLT M5 X 14	1
20	CYLINDER SPRING	1	49	ADJUSTER SPRING	4	78	FEED PISTON COVER	1	107	MAGAZINE COVER	1
21	SPRING WASHER	1	50	STEEL BALL D3.175	4	79	HEX.SOCKET BOLT M5 X 10	2	108	SAFETY GLASSES	1
22	GASKET	1	51	WASHER	1	80	MAGAZINE BUSHING	1	109	WRENCH M4	1
23	BODY ASS'Y	1	52	HEX. SOCKET HD. BOLT M6X10	1	81	SUB NAIL STOPPER	1	110	WRENCH M5	1
24	O-RING 63.6X2.5	1	53	PUSHING LEVER (A)	1	82	SUB STOPPER SPRING	1	111	WRENCH M6	1
25	PISTON BUMPER	1	54	GRIP RUBBER	1	83	NAIL GUIDE	1	112	WRENCH M8	1
26	PLUNGER SPRING	1	55	GASKET	1	84	MAIN NAIL STOPPER	1	113	OILER	1
27	O-RING 4.5X1.8	2	56	CAP	1	85	MAIN STOPPER SPRING	1			
28	PLUNGER	1	57	WASHER 5	3	86	NAIL GUIDE COVER	1			
29	O-RING 11.2X1.5	2	58	HEX. SOCKET HD. BOLT M5X20	4	87	COVER	1			

Note: If you need spare parts of this model, pls feel free to contact us or the distributor where you bought this tool. Tks!